

Koroseal Wall Protection Systems

C500-Series Crash Rail

Installation Instructions

1. Locate and install **KOROGARD**® Crash Rail in accordance with architectural drawings and specifications. When required, **KOROSEAL**® shop drawings should be used in conjunction with these documents.
2. Lay out the work to be completed, including all component parts, along the base of the wall. Check the material for any damage that may have occurred during shipment and/or handling at the job site.
3. Snap a chalk line at the proper location on the wall to ensure a level installation. Chalk line should be calculated to the center line of the top row of vertically alternating wall fasteners (see note No. 8).
4. Place the retainer in the proper position on chalk line and mark hole locations using the proper bit size for the selected wall fasteners.

NOTE: If the aluminum retainer has been supplied in stock lengths, it will be necessary for it to be field-cut. Determine the allowances necessary for door jambs, corner conditions, etc. (see back of sheet) and cut retainer to proper length. Drill proper size holes at center of retainer 3" (76.2mm) in from each end and all intermediate locations not to exceed 32" (812.8mm) O.C. Alternate holes vertically such that every other fastener is above every other fastener is below retainer centerline (see note No. 8).
5. Attach connector plates to ends of retainer using 1" (25.4mm) pan head screws as supplied.
6. Attach ends and corners with washers and machine nuts as supplied.
7. Attach splice joints with 1/4" -20 x -1-1/2" (38.1mm) machine screws, washers, and nuts as supplied.
8. Mount assembly to wall using proper fasteners (not included). Anchoring centerlines are offset vertically from centerline of retainer. Alternate vertical anchor locations such that every other fastener is above and every other fastener is below retainer centerline. Tighten securely.

NOTE: Prior to installation of the KOROGARD cover, make sure that all fasteners are secure and properly seated.
9. Hold the **KOROGARD** cover at an angle and place the top of the cover behind the top of the retainer. Make sure that the cover is placed in the proper position and snap-fit the **KOROGARD** cover onto the aluminum retainer by placing hands downward and applying pressure with the heel of each hand to force the cover onto the retainer. Continue along until the complete length of the cover is securely installed.
10. If you have any questions during installation, please call your local **KOROGARD** representative.

NOTE: If the KOROGARD cover has been supplied in stock lengths, it will be necessary for it to be field-cut. Determine the distance from inside cap to inside cap. It is recommended that the KOROGARD cover be cut slightly oversize to provide proper alignment between the end caps. When cutting the KOROGARD cover, it is recommended that a connector plate be placed inside and directly adjacent to the cut location to prevent distortion of the cover during cutting.

Mounting cushions vary based on model number:

C500 Flush Mount

C520 1/8" Mounting Cushion

C530 1/2" Mounting Cushion (shown)

C540 1-1/2" Mounting Brackets

C550 2" Mounting Brackets

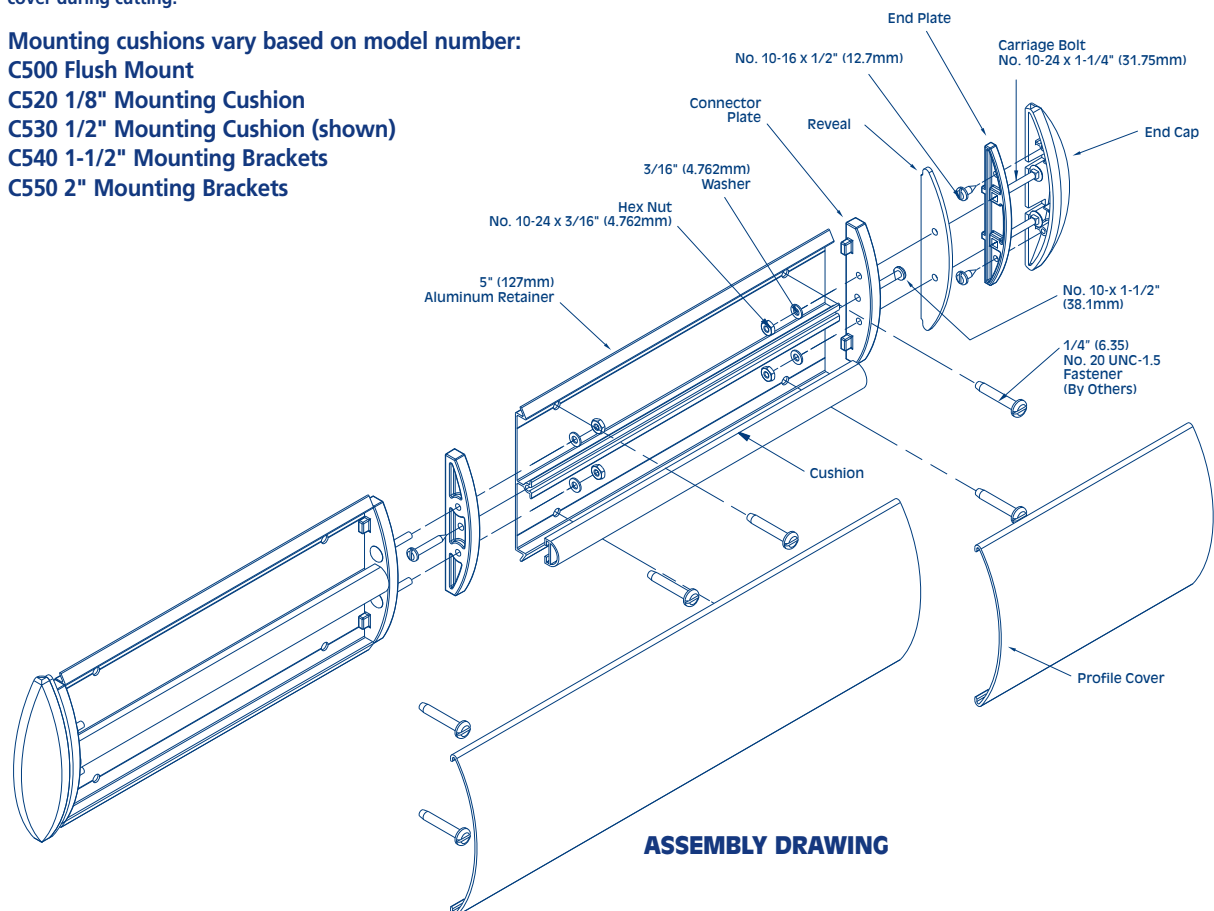

ASSEMBLY DRAWING

Installation Dimensions for C500-Series Crash Rail

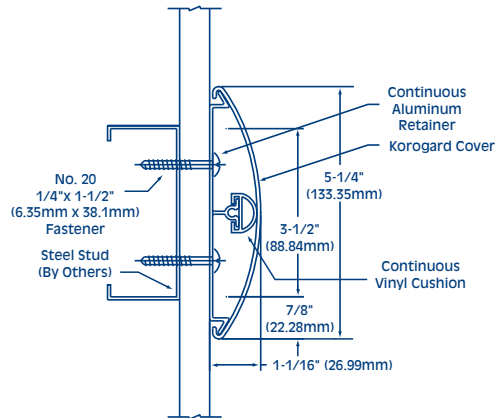

MODEL C500

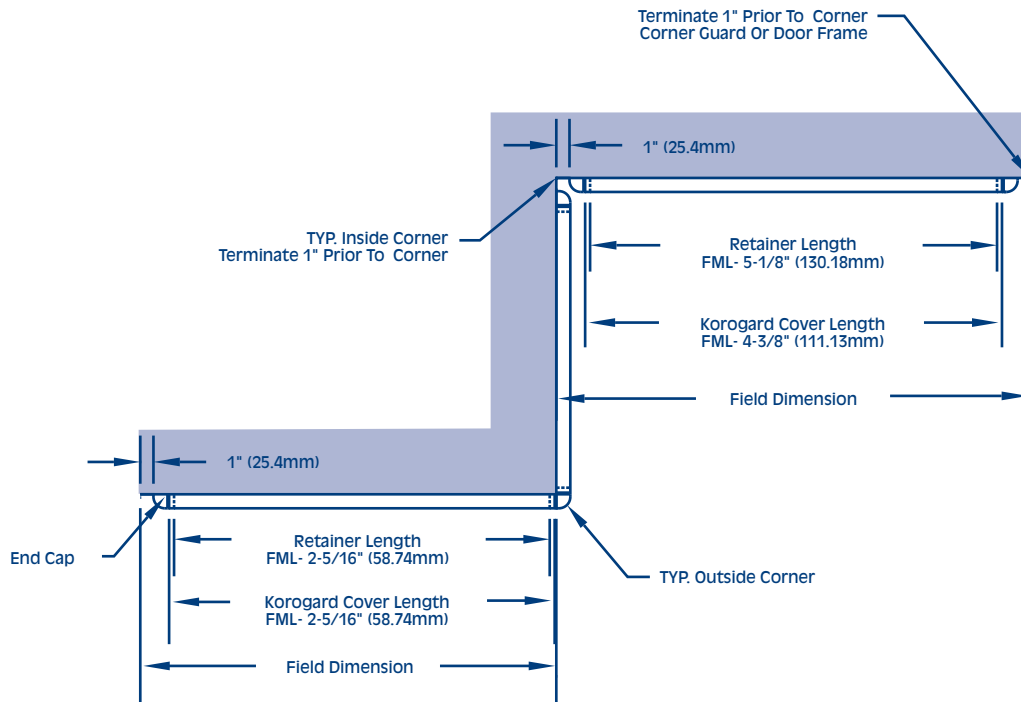

PLAN VIEW



800-628-0449 • www.korogard.com • Division 10 26 00