

Koroseal Wall Protection Systems

C400-Series Crash Rail

Installation Instructions

1. Locate and install **KOROGARD**® Crash Rail in accordance with architectural drawings and specifications. When required, **KOROGARD** shop drawings should be used in conjunction with these documents.
2. Lay out the work to be completed, including all component parts, along the base of the wall. Check the material for any damage that may have occurred during shipment and/or handling at the job site.
3. Snap a chalk line at the proper location on the wall to ensure a level installation. Chalk line should be calculated to the center line of the mounting bracket wall fasteners.
4. Place the retainer in the proper position on the chalk line and mark hole locations using the proper bit size for fasteners.
NOTE: If the aluminum retainer has been supplied in stock lengths, it will be necessary for it to be field-cut. Determine the allowances necessary for door jambs, corner conditions, etc. (see back of sheet) and cut retainer to proper length. Drill proper size holes at center of retainer 3" (76.2mm) in from each end and all intermediate locations not to exceed 32" (812.8mm) O.C.
5. Attach connector plates to ends of retainer using 1" (25.4mm) pan head screws.
6. Attach ends and corners with washer and machine nuts as required.
7. Attach splice joints with #10 x 1-1/2" (38.1mm) machine screws, washers, and nuts.
8. Mount assembly to wall using proper fasteners (not included). Tighten securely.
NOTE: Prior to installation of the KOROGARD cover, make sure that all fasteners are secure and properly seated.
9. Hold the **KOROGARD** cover at an angle and place the top of the cover behind the top of the retainer. Make sure that the cover is placed in the proper position and snap-fit the **KOROGARD** cover onto the aluminum retainer by placing hands downward and applying pressure with the heel of each hand to force the cover onto the retainer. Continue along until the complete length of the cover is securely installed.
10. If you have any questions during installation, please call your local **KOROGARD** representative.
NOTE: If the KOROGARD cover has been supplied in stock lengths, it will be necessary for it to be field-cut. Determine the distance from inside cap to inside cap. It is recommended that the KOROGARD cover be cut slightly oversize to provide proper alignment between the end caps.

Mounting cushions or brackets vary based on model number:

C400 Flush Mount

C420 1/8" (3.18mm) Mounting Cushion

C430 1/2" (12.7mm) Mounting Cushion (shown)

C440 1-1/2" (38.1mm) Mounting Brackets

C450 2" (50.8mm) Mounting Brackets

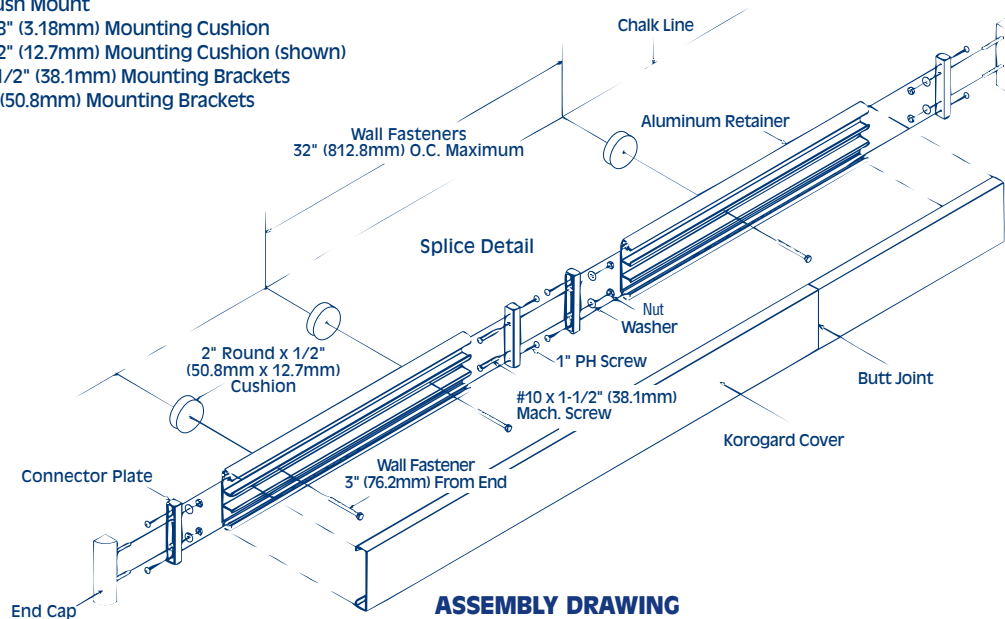

Installation Dimensions for C400-Series Crash Rail

NOTE: Includes Crash Rail Model C400 Flush Mount
 Model C420 1/8" (3.18mm) Mounting Cushion
 Model C430 1/2" (12.7mm) Mounting Cushion
 Model C440 1-1/2" (38.1mm) Mounting Bracket
 Model C450 2" (50.8mm) Mounting Bracket

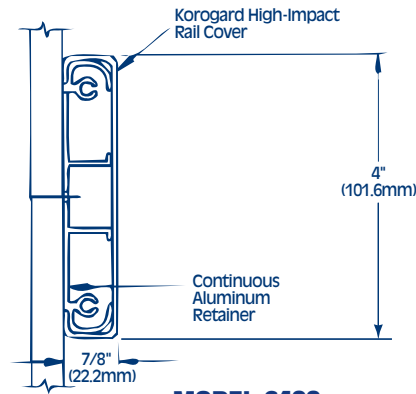

MODEL C400

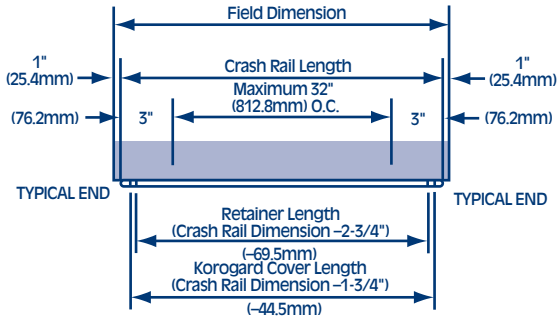

TYPICAL STRAIGHT LENGTH

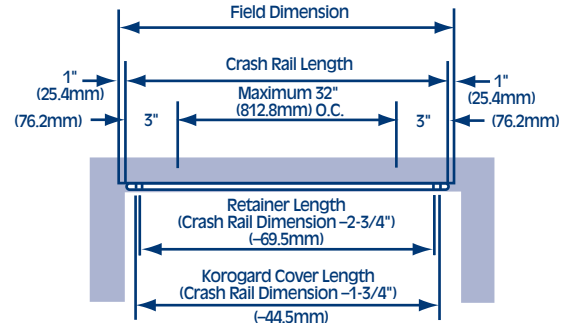

TYPICAL STRAIGHT LENGTH WITH TYPICAL ENDS

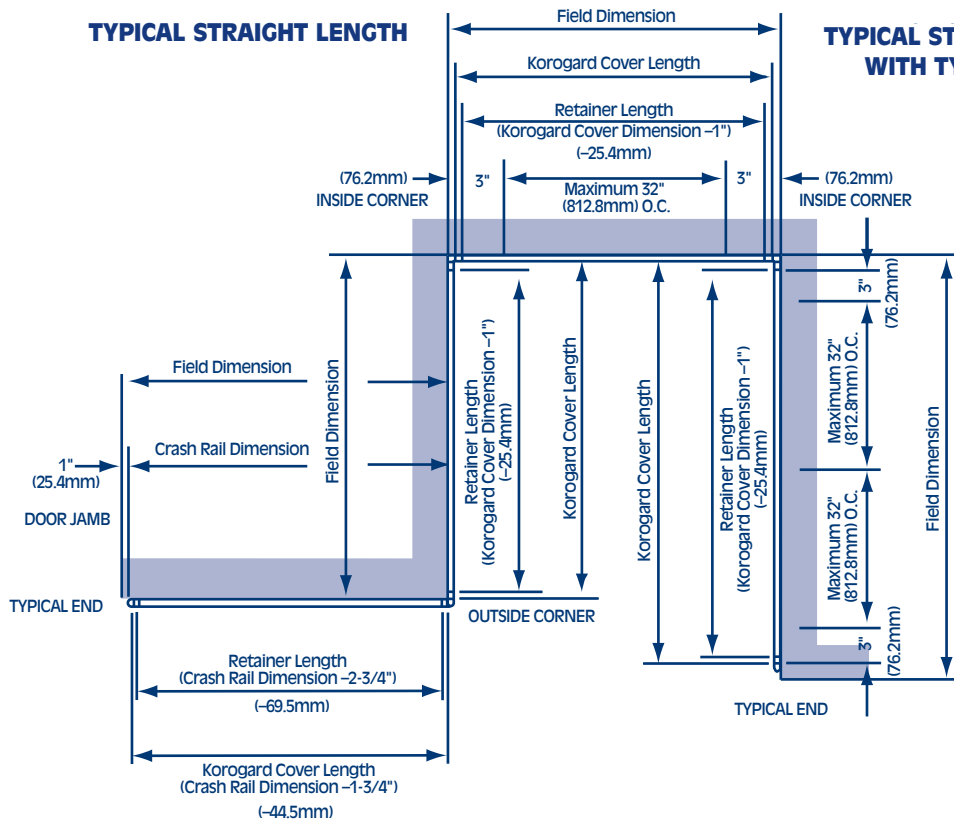

KOROGARD®
 WALL PROTECTION SYSTEMS

800-628-0449 • www.korogard.com • Division 10 26 00